



Fastener
Solutions

8" Slim Line Cable Ties Marketing Specifications

For the following part numbers:

10325-0

10326-0

10327-0

10328-0

10330-0

August 1, 2018

AVERY DENNISON MARKETING SPECIFICATION

THE SUBJECT MATTER DISCLOSED HEREIN EMBODIES PROPRIETARY INFORMATION WHICH IS THE CONFIDENTIAL PROPERTY OF THE AVERY DENNISON CO. NONE OF WHICH SHALL BE COPIED, REPRODUCED, DISCLOSED TO OTHERS, PUBLISHED OR USED IN WHOLE OR IN PART, FOR ANY PURPOSE OTHER THAN THAT FOR WHICH IT IS BEING MADE AVAILABLE WITHOUT THE EXPRESS ADVANCE WRITTEN PERMISSION OF A DULY AUTHORIZED AGENT OF THE COMPANY. THIS DOCUMENT IS THE PROPERTY OF THE AVERY DENNISON CO. AND IS TO BE RETURNED TO THE COMPANY ON DEMAND.

HISTORY		DESCRIPTION
REV. P	DATE 2.25.15	REDRAWN IN NEW FORMAT, ADDED UL INFORMATION AND LOGO

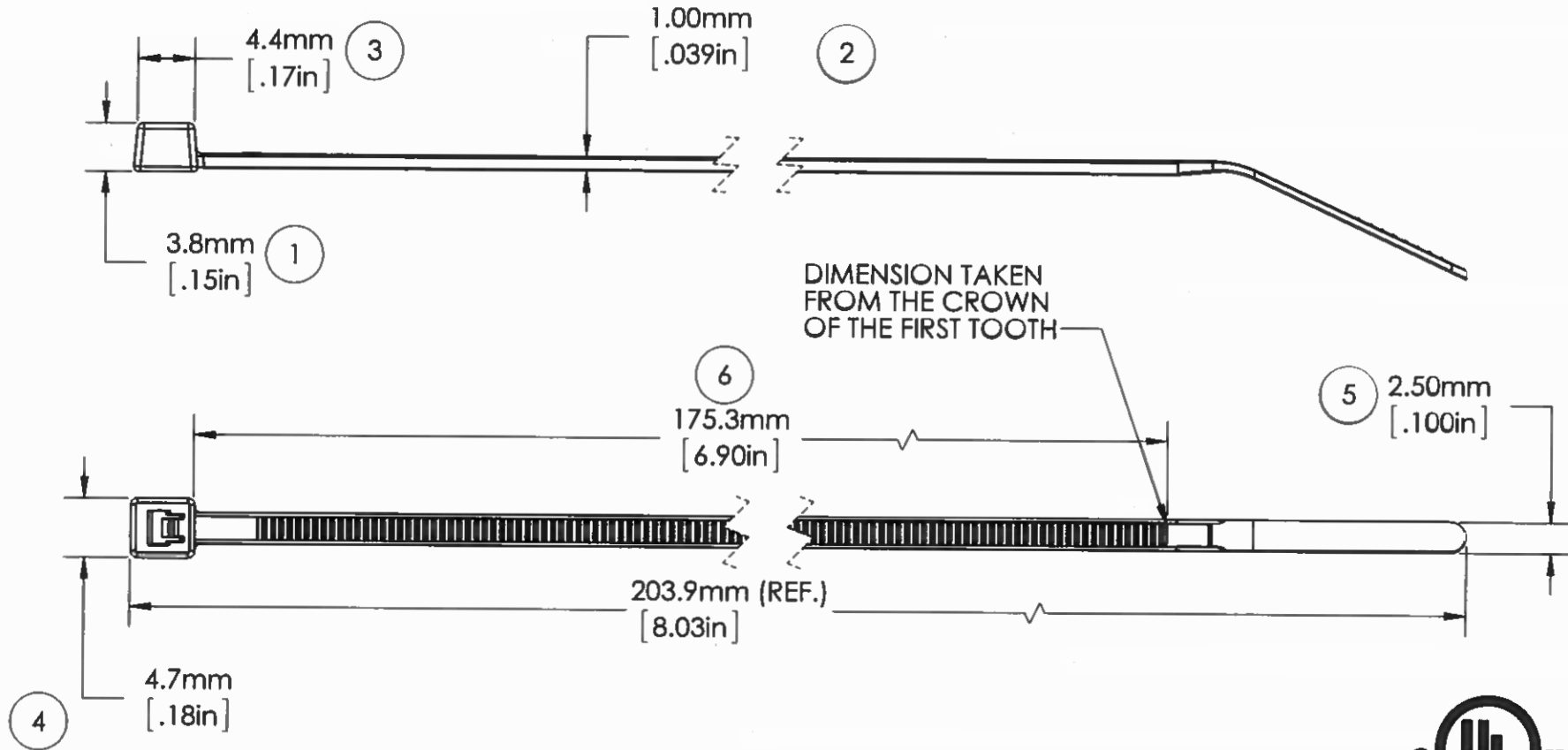

NOTE: THESE CABLE TIES ARE PLENUM RATED AND HAVE A FLAMMABILITY RATING OF V-2



LOOP TENSILE STRENGTH:	18 LBF/80 N MIN. PER AS-23190
MILITARY STANDARD:	MS-3367-4-9
OPERATING TEMP RANGE:	-4°F (-20°C) TO 185°F (85°C)
MIN. INSTALLATION TEMP:	32°F (0°C)
WEIGHT:	0.49g. / (0.01672 oz)
BUNDLE DIAMETER:	Ø 1.6mm TO Ø 54mm (0.06" - 2.13")
TOOL:	12001-0 - HAND TOOL 12500-0 - PNEUMATIC TOOL
TOOL TENSION SETTING:	1-3
PACKAGING:	1000/BAG, 5000/CASE

APPROVALS:	ENG. APPR. <i>[Signature]</i>	2/26/15
	Q.A. APPR. <i>[Signature]</i>	2/25/15

SPECIFIED TOLERANCES ARE:	
.XX ± .03 INCHES	.X ± .7 MM
.XXX ± .010 INCHES	.XX ± .25 MM
ANGULAR: ± 2°	

MATERIAL	NYLON 6/6
COLOR	NATURAL

AVERY DENNISON <small>FASINER DIVISION FITCHBURG, MA 01420 U.S.A. TEL. 1-800-225-5913 FAX. 978-353-8157</small>	DESCRIPTION	STOCK NO.	REV.
	8" CABLE TIE, SLIM-LINE	10325-0	P

5

4

3

2

1

AVERY DENNISON MARKETING SPECIFICATION

HISTORY

REV.	DATE	DESCRIPTION
P	2.25.15	REDRAWN IN NEW FORMAT, ADDED UL INFORMATION AND LOGO

THE SUBJECT MATTER DISCLOSED HEREIN EMBODIES PROPRIETARY INFORMATION WHICH IS THE CONFIDENTIAL PROPERTY OF THE AVERY DENNISON CO. NONE OF WHICH SHALL BE COPIED, REPRODUCED, DISCLOSED TO OTHERS, PUBLISHED OR USED IN WHOLE OR IN PART, FOR ANY PURPOSE OTHER THAN THAT FOR WHICH IT IS BEING MADE AVAILABLE WITHOUT THE EXPRESS ADVANCE WRITTEN PERMISSION OF A DULY AUTHORIZED AGENT OF THE COMPANY. THIS DOCUMENT IS THE PROPERTY OF THE AVERY DENNISON CO. AND IS TO BE RETURNED TO THE COMPANY ON DEMAND.

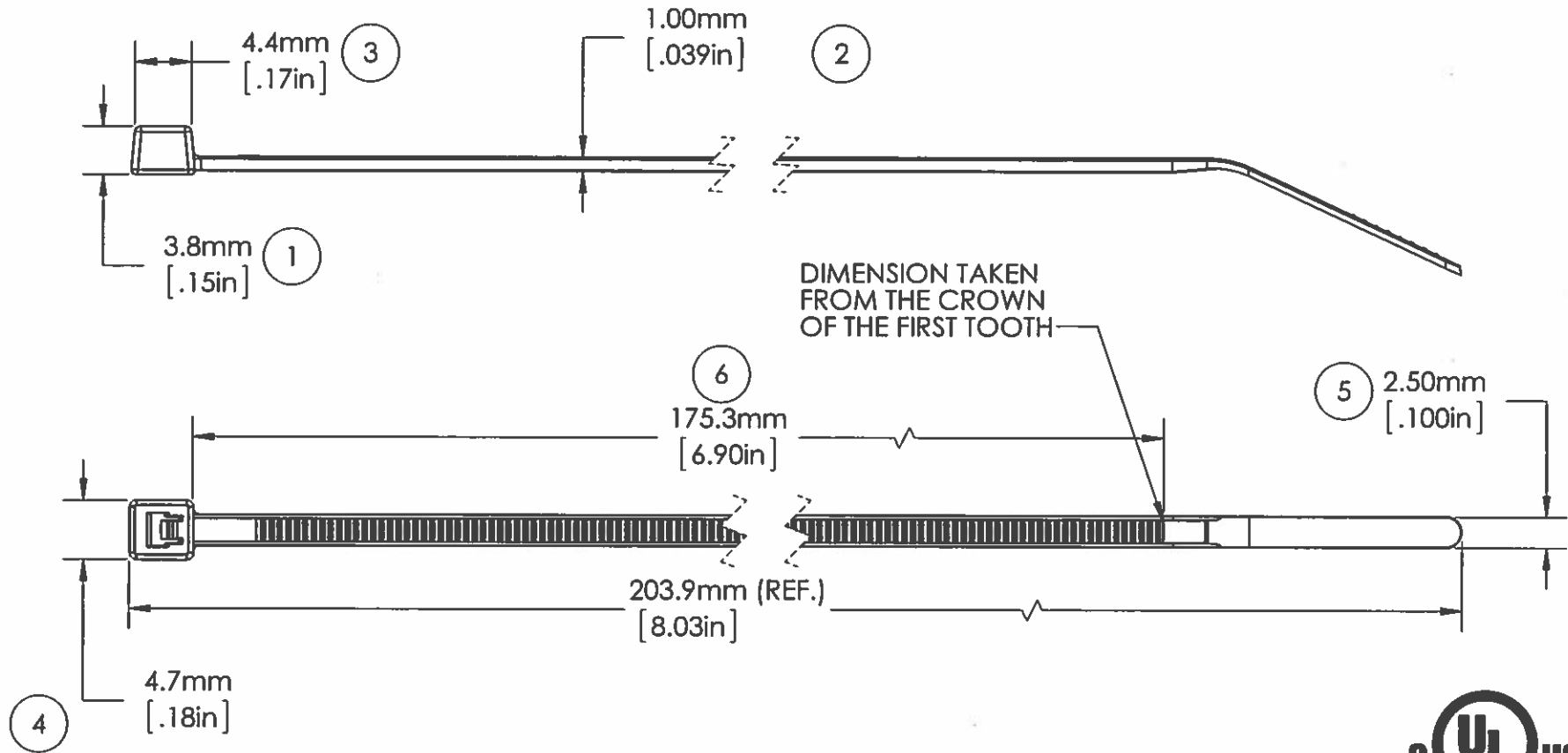

NOTE: THESE CABLE TIES ARE PLENUM RATED AND HAVE A FLAMMABILITY RATING OF V-2

LOOP TENSILE STRENGTH:	18 LBF/80 N MIN. PER AS-23190
MILITARY STANDARD:	N/A
OPERATING TEMP RANGE:	-40°F (-40°C) TO 221°F (105°C)
MIN. INSTALLATION TEMP:	32°F (0°C)
WEIGHT:	0.49g. / (0.01672 oz)
BUNDLE DIAMETER:	Ø 1.6mm TO Ø 54mm (0.06" -2.13")
TOOL:	12001-0 - HAND TOOL 12500-0 - PNEUMATIC TOOL
TOOL TENSION SETTING:	1-3
PACKAGING:	1000/BAG, 5000/CASE

APPROVALS: ENG. APPR. *[Signature]* 2/26/15
Q.A. APPR. *[Signature]* 2/26/15

SPECIFIED TOLERANCES ARE:	
.XX ± .03 INCHES	.X ± .7 MM
.XXX ± .010 INCHES	.XX ± .25 MM
ANGULAR: ± 2°	

MATERIAL	NYLON 6/6
COLOR	BLACK, HEAT STABILIZED

AVERY DENNISON <small>FASTENER DIVISION FITCHBURG, MA 01420 U.S.A. TEL. 1-800-225-5913 FAX. 978-353-8157</small>	DESCRIPTION	STOCK NO.	REV.
	8" CABLE TIE, SLIM-LINE	10326-0	P

5

4

3

2

1

AVERY DENNISON MARKETING SPECIFICATION

HISTORY

REV.	DATE	DESCRIPTION
P	2.25.15	REDRAWN IN NEW FORMAT, ADDED UL INFORMATION AND LOGO

THE SUBJECT MATTER DISCLOSED HEREIN EMBODIES PROPRIETARY INFORMATION WHICH IS THE CONFIDENTIAL PROPERTY OF THE AVERY DENNISON CO. NONE OF WHICH SHALL BE COPIED, REPRODUCED, DISCLOSED TO OTHERS, PUBLISHED OR USED IN WHOLE OR IN PART, FOR ANY PURPOSE OTHER THAN THAT FOR WHICH IT IS BEING MADE AVAILABLE WITHOUT THE EXPRESS ADVANCE WRITTEN PERMISSION OF A DULY AUTHORIZED AGENT OF THE COMPANY. THIS DOCUMENT IS THE PROPERTY OF THE AVERY DENNISON CO. AND IS TO BE RETURNED TO THE COMPANY ON DEMAND.

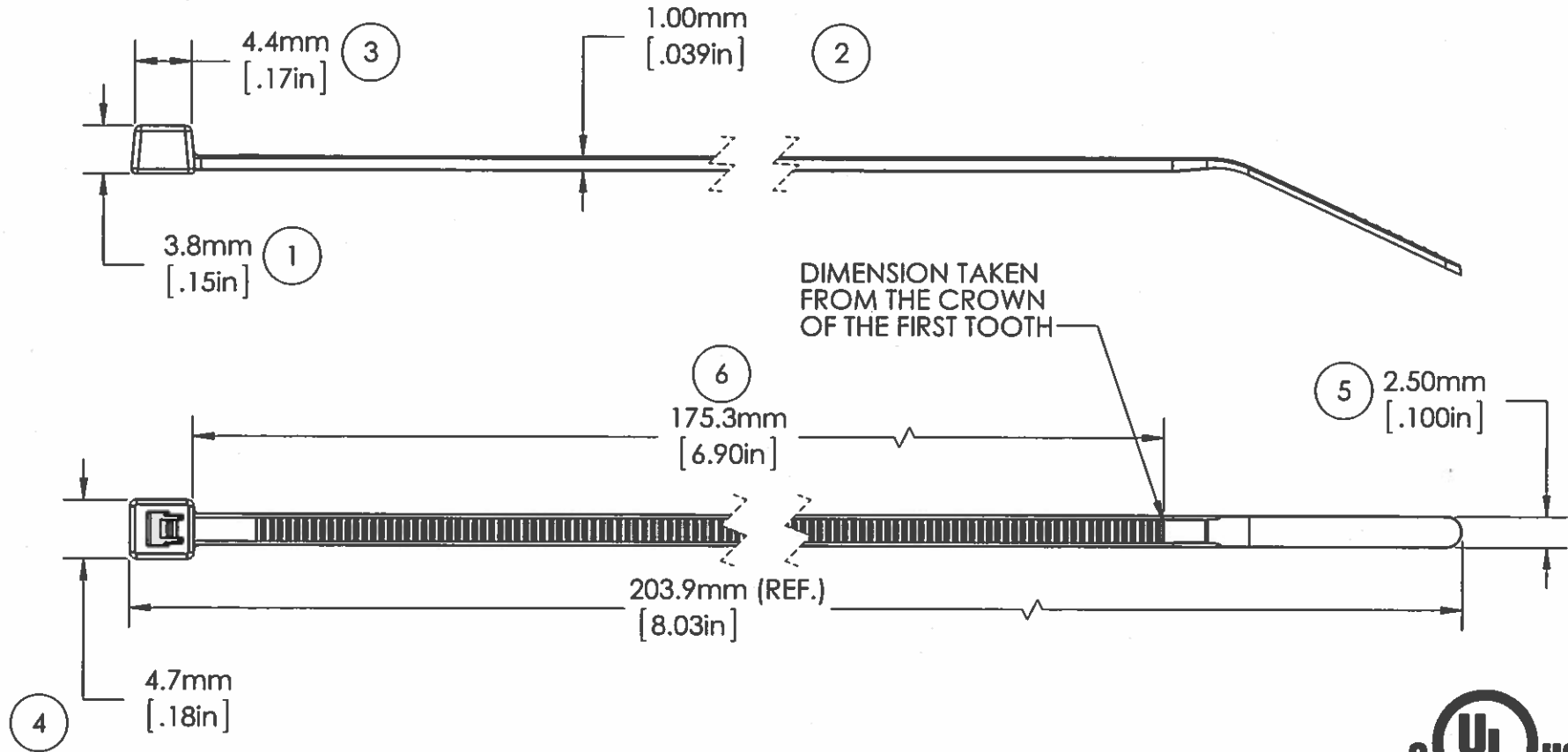

NOTE: THESE CABLE TIES ARE UV RESISTANT AND HAVE A FLAMMABILITY RATING OF V-2



LOOP TENSILE STRENGTH:	18 LBF/80 N MIN. PER AS-23190
MILITARY STANDARD:	MS-3367-4-0
OPERATING TEMP RANGE:	-40°F (-40°C) TO 176°F (80°C)
MIN. INSTALLATION TEMP:	32°F (0°C)
WEIGHT:	0.49g / (0.01672 oz)
BUNDLE DIAMETER:	Ø 1.6mm TO Ø 54mm (0.06" - 2.13")
TOOL:	12001-0 - HAND TOOL 12500-0 - PNEUMATIC TOOL
TOOL TENSION SETTING:	1-3
PACKAGING:	1000/BAG, 5000/CASE

APPROVALS: ENG. APPR. *[Signature]* 2/26/15
Q.A. APPR. *[Signature]* 2/26/15

SPECIFIED TOLERANCES ARE:
 .XX ± .03 INCHES .X ± .7 MM
 .XXX ± .010 INCHES .XX ± .25 MM
 ANGULAR: ± 2°

MATERIAL
NYLON 6/6
 COLOR
BLACK, WEATHER RESISTANT

AVERY DENNISON <small>FASTENER DIVISION FRITCHBURG, MA 01420 U.S.A. TEL. 1-800-225-5913 FAX. 978-353-8157</small>	DESCRIPTION	STOCK NO.	REV.
	8" CABLE TIE, SLIM-LINE	10327-0	P

AVERY DENNISON MARKETING SPECIFICATION

THE SUBJECT MATTER DISCLOSED HEREIN EMBODIES PROPRIETARY INFORMATION WHICH IS THE CONFIDENTIAL PROPERTY OF THE AVERY DENNISON CO. NONE OF WHICH SHALL BE COPIED, REPRODUCED, DISCLOSED TO OTHERS, PUBLISHED OR USED IN WHOLE OR IN PART, FOR ANY PURPOSE OTHER THAN THAT FOR WHICH IT IS BEING MADE AVAILABLE WITHOUT THE EXPRESS ADVANCE WRITTEN PERMISSION OF A DULY AUTHORIZED AGENT OF THE COMPANY. THIS DOCUMENT IS THE PROPERTY OF THE AVERY DENNISON CO. AND IS TO BE RETURNED TO THE COMPANY ON DEMAND.

HISTORY

REV.	DATE	DESCRIPTION
P	2.25.15	REDRAWN IN NEW FORMAT, ADDED UL INFORMATION AND LOGO

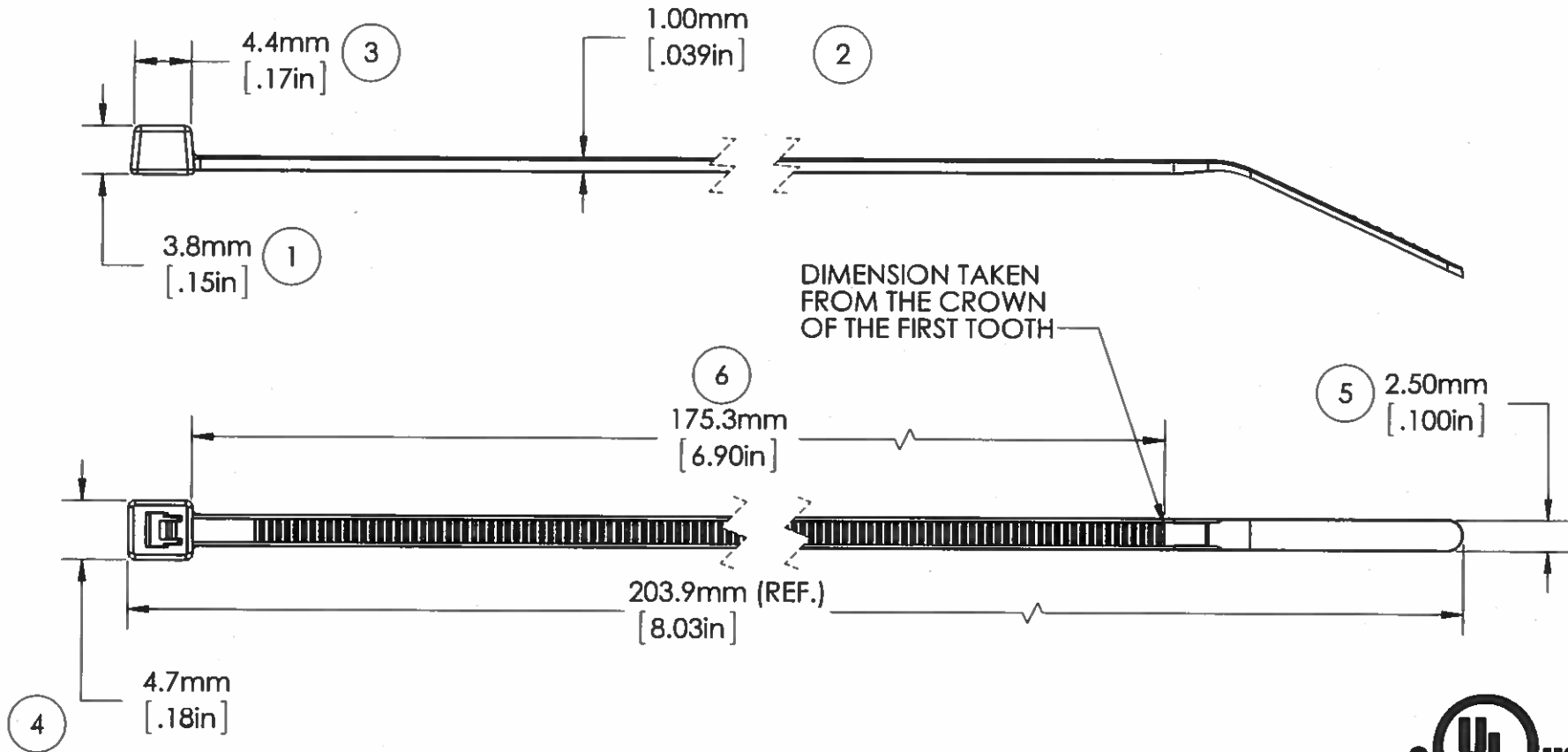

NOTE: THESE CABLE TIES ARE PLENUM RATED AND HAVE A FLAMMABILITY RATING OF V-2



LISTED
POSITIONING DEVICE
E57800
TYPE 21

LOOP TENSILE STRENGTH:	18 LBF/80 N MIN. PER AS-23190
MILITARY STANDARD:	MS-3367-4-9
OPERATING TEMP RANGE:	-4°F (-20°C) TO 185°F (85°C)
MIN. INSTALLATION TEMP:	32°F (0°C)
WEIGHT:	0.49g. / (0.01672 oz)
BUNDLE DIAMETER:	Ø 1.6mm TO Ø 54mm (0.06" - 2.13")
TOOL:	12001-0 - HAND TOOL 12500-0 - PNEUMATIC TOOL
TOOL TENSION SETTING:	1-3
PACKAGING:	100/BAG, 5000/CASE

APPROVALS:	ENG. APPR. <i>[Signature]</i> 2/26/15	SPECIFIED TOLERANCES ARE:	MATERIAL	DESCRIPTION
	Q.A. APPR. <i>[Signature]</i> 2/26/15		NYLON 6/6	
		.XX ± .03 INCHES .X ± .7 MM	COLOR	
		.XXX ± .010 INCHES .XX ± .25 MM	NATURAL	STOCK NO.
		ANGULAR: ± 2°		10328-0

	FASTENER DIVISION FITCHBURG, MA 01420 U.S.A. TEL. 1-800-225-5913 FAX. 978-353-8157
--	---

5

4

3

2

1

